

EMSD.ORG

Mobile Messaging Landscape Services, Technologies, Protocols, Products, and the Medium

Mohsen Banan
<mohsen@neda.com>

Outline

- **Current Landscape** 
- **Basic Concepts & Terminology**
- **Internet E-Mail**
- **Paging**
- **TeleCom / Cellular**
- **Ad-Hoc Packet Data**
- **EMSD**
- **Moving Forward**

Internet E-Mail Rules

- **Can't live without E-mail**
- **100s of millions of INBOXes established**
- **Message Exchange Formats established & firmly in place**
- **A good size INDUSTRY has already been built around Internet E-mail**
- **Mobile Messaging is in its infancy**

Mobile Messaging Is Next

- Mobile Messaging is Urgent & Important E-mail “pushed” to you
- (Mobile) Cell Phones are to: Fixed Phones,
What
(Mobile) Two-Way Paging is to: Fixed Email
- Two-Way Paging, E-mail, Fax, VoiceMail,.. are all on the same continuum
- Mobile Messaging is the Killer Application for Wide-Area Wireless Networking

Current Mobile Messaging Systems

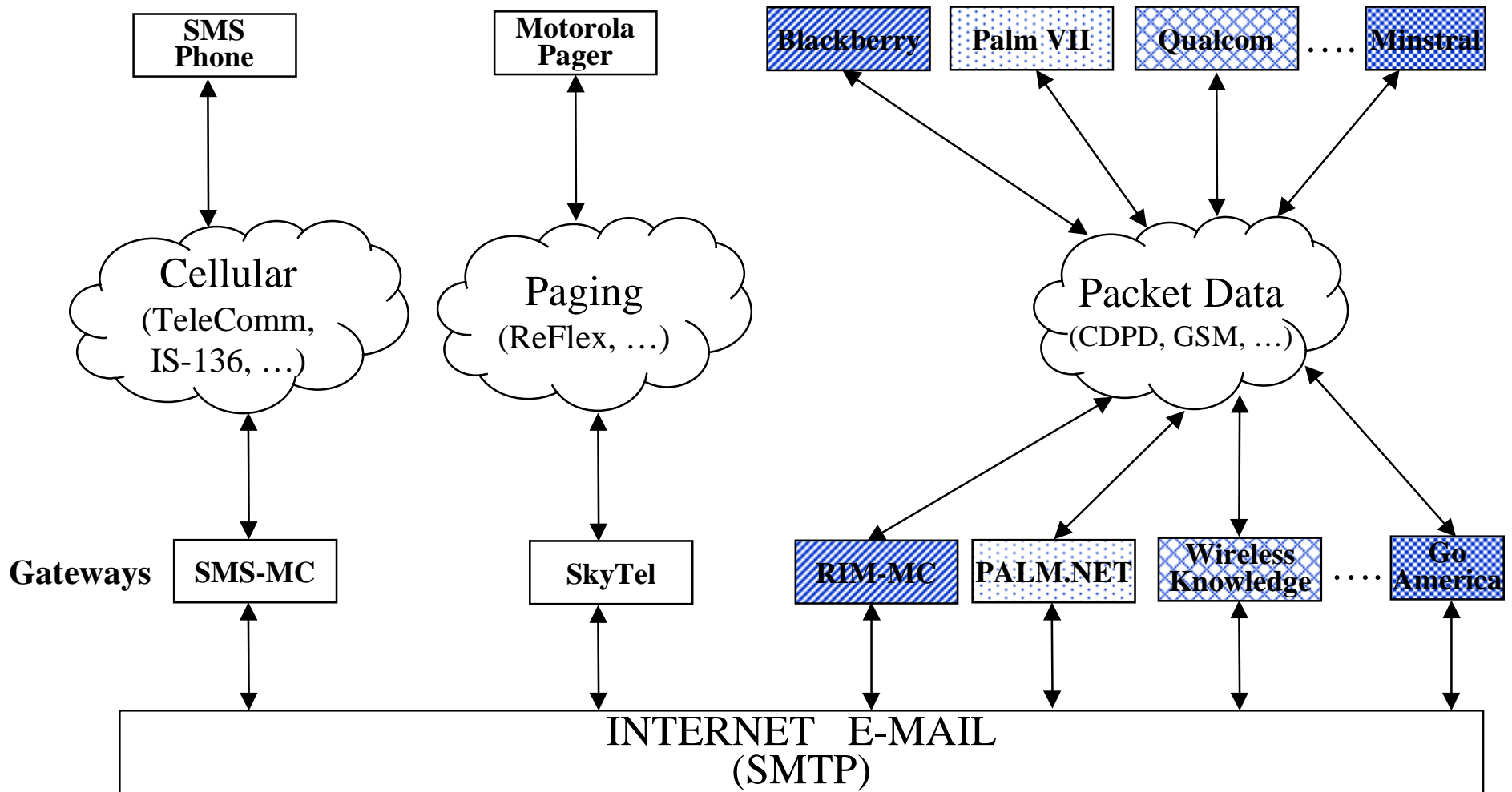

Advantages Of Wearable Email

Wearable PagingMail

- **Submission (Sending)**
 - Email
- **Delivery (Pushed Receive)**
 - Pager Like Email (Urgent & Important Email)
 - Pager Like Notifications (Voice Mail Notification, ...)

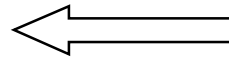
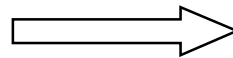

Rest Of The World

- **Mail Retrieval (Receiving)**
 - Email, Fax, Web-Base Msg. Retrieval, Voice Messaging, ...
- **Submission (Sending)**
 - Email, Web-Base Msg. Origination, Interactive Voice Response, Fax, ...

- **Unconscious Carry**
- **Increased Responsiveness**
- **Faster Problem Solving**

- **Improved Information Flow**
- **Enhanced Productivity**

The Opportunity Is Huge

- **“The Yankee Group in Boston forecast sales of two-way pagers to hit 5 million next year, 24 million by 2001 and 54 million by 2003” (Wireless Week Aug.31, 1998)**
- **The Yankee Group estimates that there will be nearly seven million wireless and mobile data subscribers by 1999, increasing to more than 21 million by 2002. (3Com web site-News & Promotions)**

Two-Way Paging Subscribers

Two-Way Paging Subscribers Growth

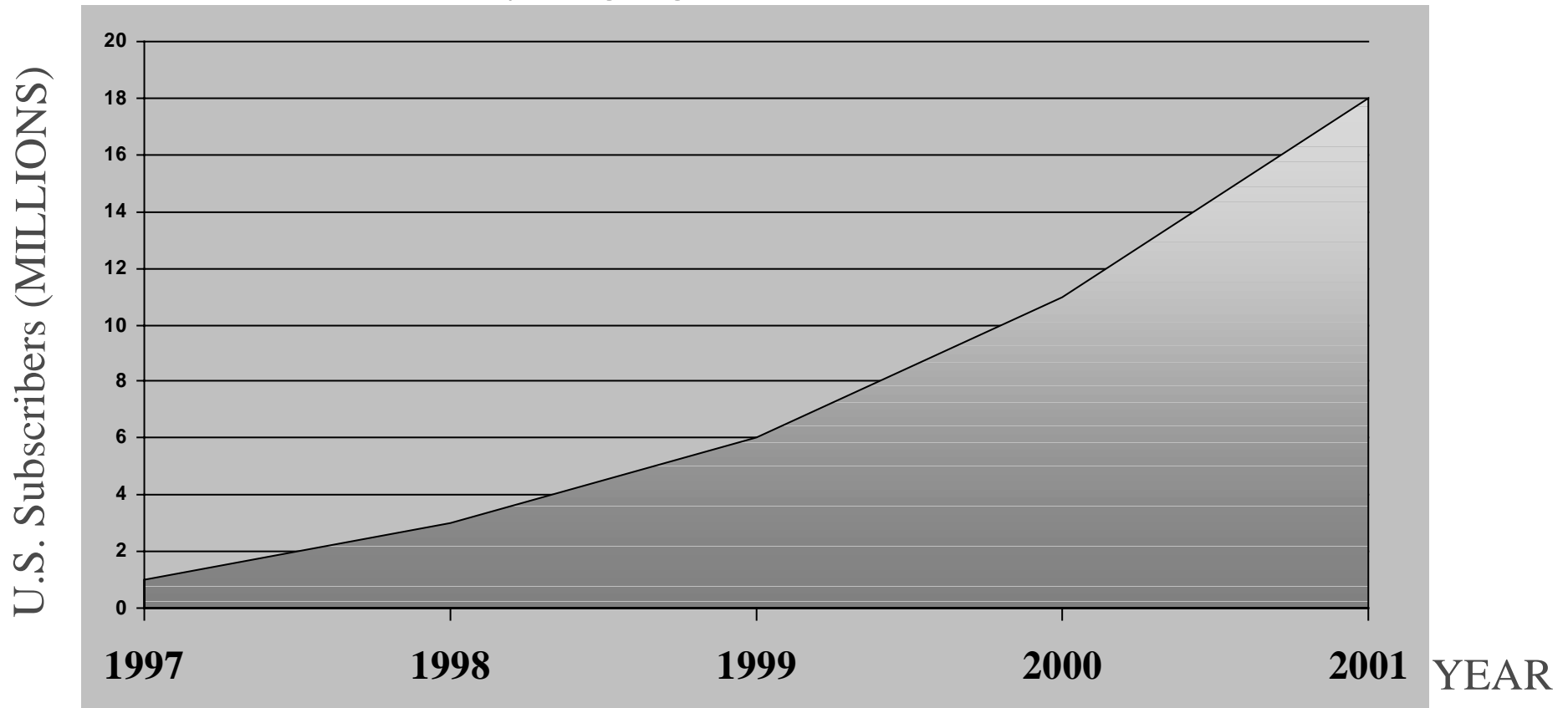

SOURCE: Donaldson, Lufkin & Jenrette Securities Corp

The Wireless Internet Explosion

The Global Revenue for wireless access to the Internet and Intranet-Centered Services
Equipment, and Software: 1997 to 2002

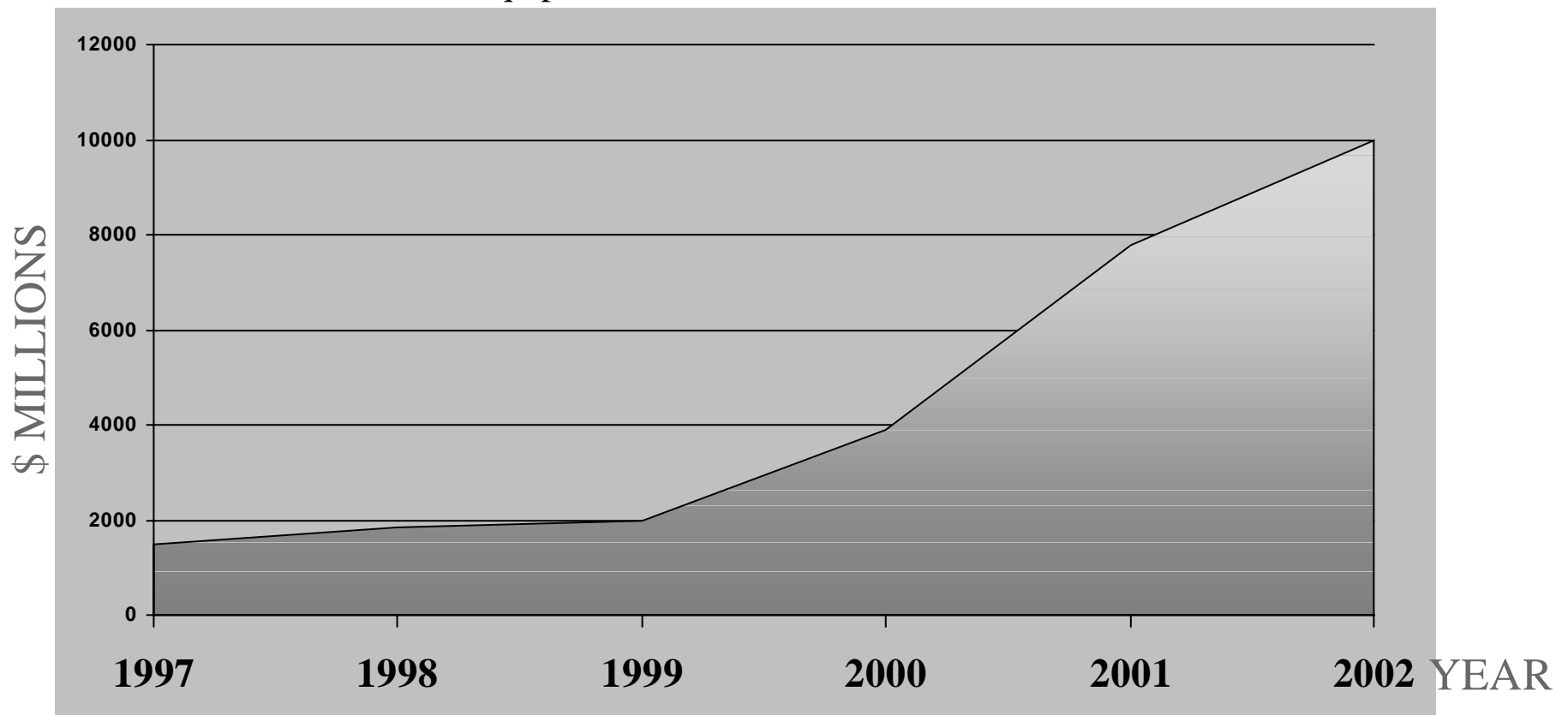

SOURCE: Killen & Associates, Inc

Two-Way Digital Technologies

Two-Way Paging Networks	Voice & Data Networks	Packet Networks
- ReFLEX 50 - ReFLEX 25	- CDMA - GSM - TDMA - iDEN	- DataTAC (American Mobile) - Mobitex (BellSouth Wireless Data) - CDPD - Metricom

Today's Wireless Service Providers

Two-Way Nationwide Data-Only Networks	Satellite Data
<ul style="list-style-type: none">- American Mobile (formally ARDIS)- BellSouth Wireless Data (formally RAM)	<ul style="list-style-type: none">- SkyTel- PageNet- PageMart-
Regional Data-Only Networks	Two-Way Paging Services
<ul style="list-style-type: none">- Metricom- CDPD (AT&T), Ameritech, Bell Atlantic, GTE MobilNet)	<ul style="list-style-type: none">- Orbcomm- American Mobile- Globalstar

Wireless Data Services

	<u>Availability</u>	<u>Monthly Cost</u>	<u>Nationwide</u>	<u>Roaming</u>
<u>Two-Way Messaging/Data-Only</u>				
American Mobile	NOW	25-100	Yes	Yes
BellSouth WD	NOW	25-100	Yes	Yes
CDPD	NOW	25-100	No	Yes ¹
Metricom	NOW	20-50	No	Yes ²
Cellular	NOW	Access +	Yes	Yes ³
<u>Two-Way Paging</u>				
SkyTel	NOW	25-99	Yes	Yes
PageNet	NOW	25-99	Yes	Yes
PageMart	NOW	25-99	Yes	Yes

- ¹ CDPD covers 52% of United States business population
- ² Metricom coverage in Silicon Valley, Seattle, Wash. DC, and University Campuses
- ³ Dial-up analog cellular service
- ⁴ PageNet is currently reselling SkyTel two-way service

Outline

- **Current Landscape**
- **Basic Concepts & Terminology** 
- **Internet E-Mail**
- **Paging**
- **TeleCom / Cellular**
- **Ad-Hoc Packet Data**
- **EMSD**
- **Moving Forward**

E-Mail Format Standards

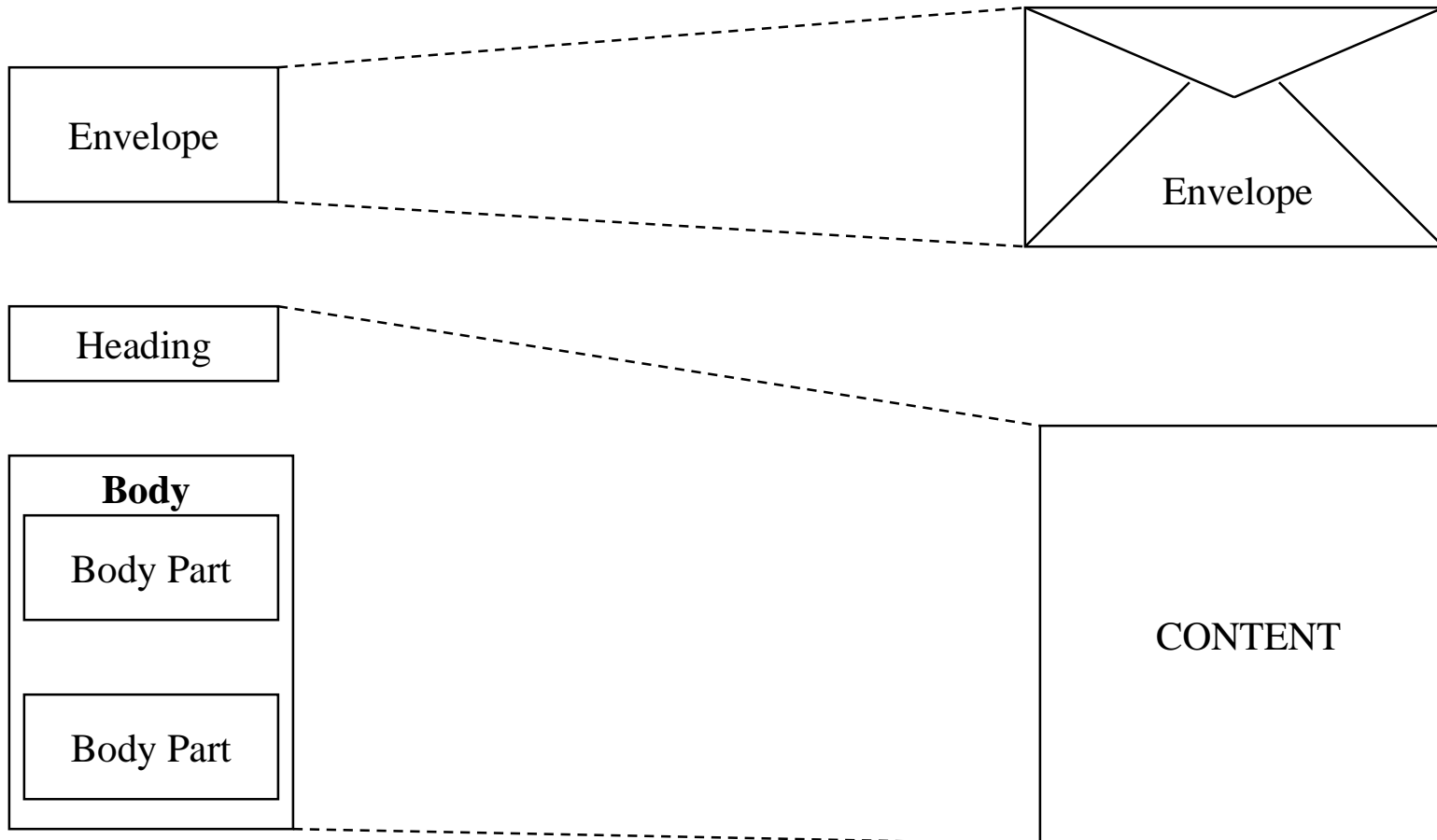

Messaging System Architecture

MESSAGE HANDLING SYSTEM

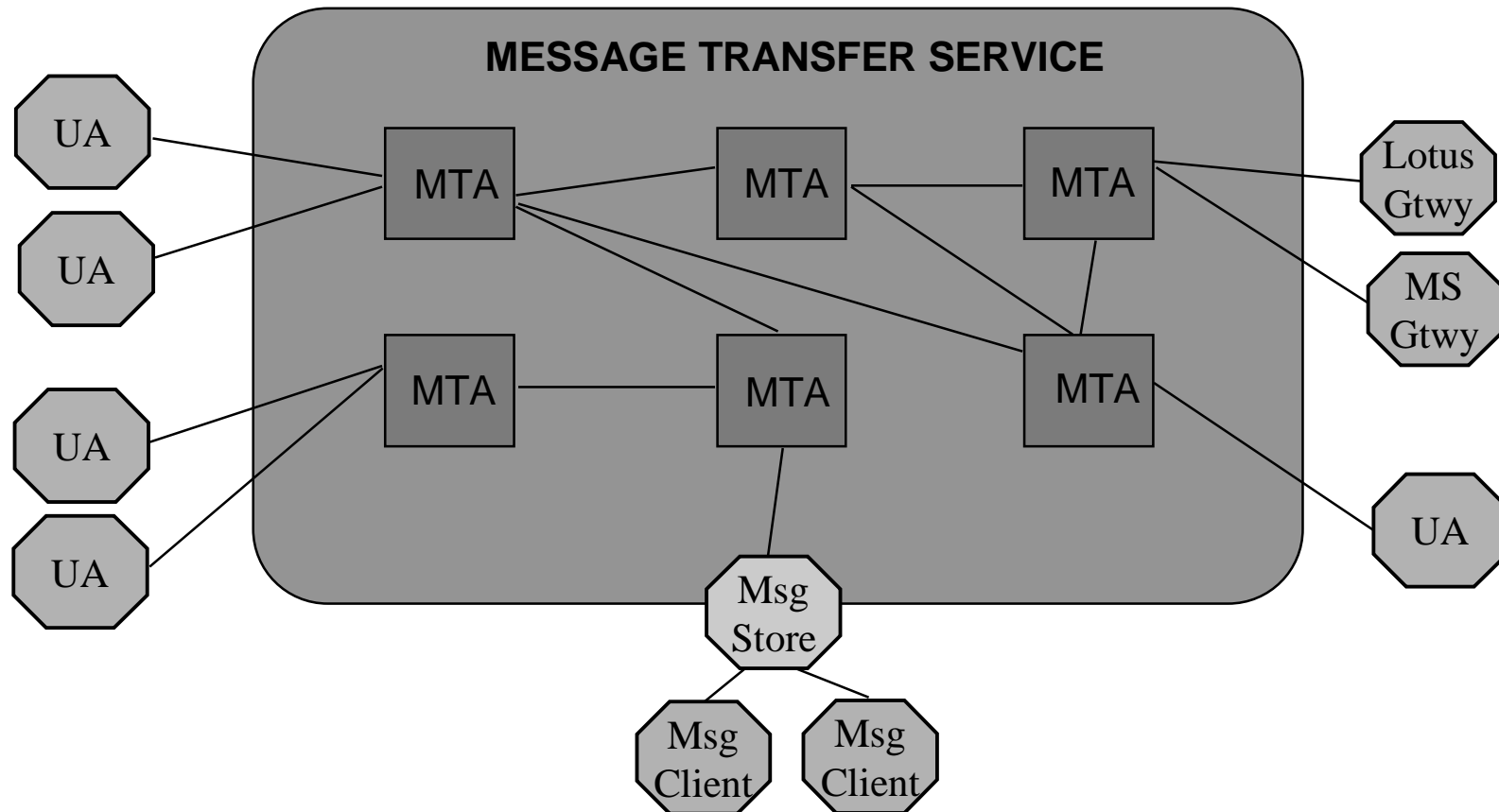

When and Where Dimensions of Messaging

- **Interpersonal Communication
(Who=man)**

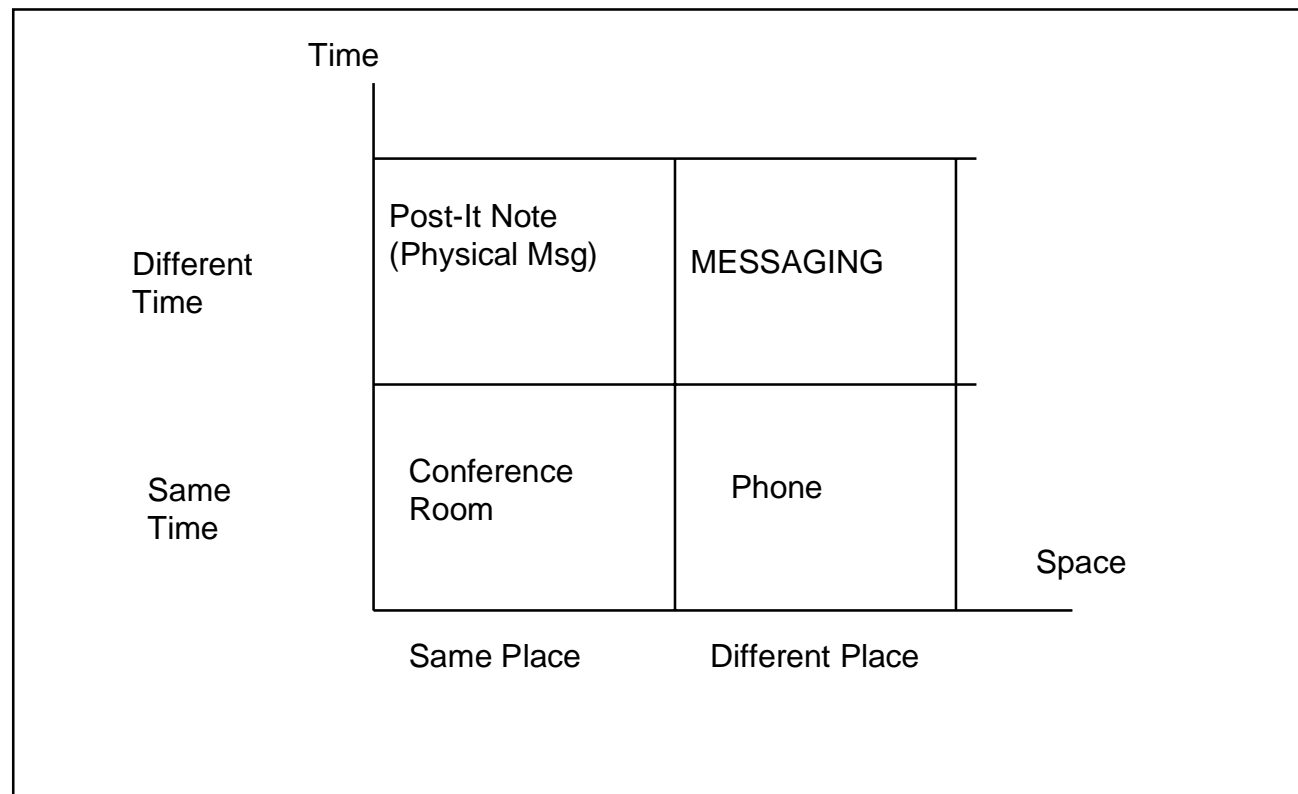

The Who Dimension of Messaging

- **Non Intrusive (different time, different place)**

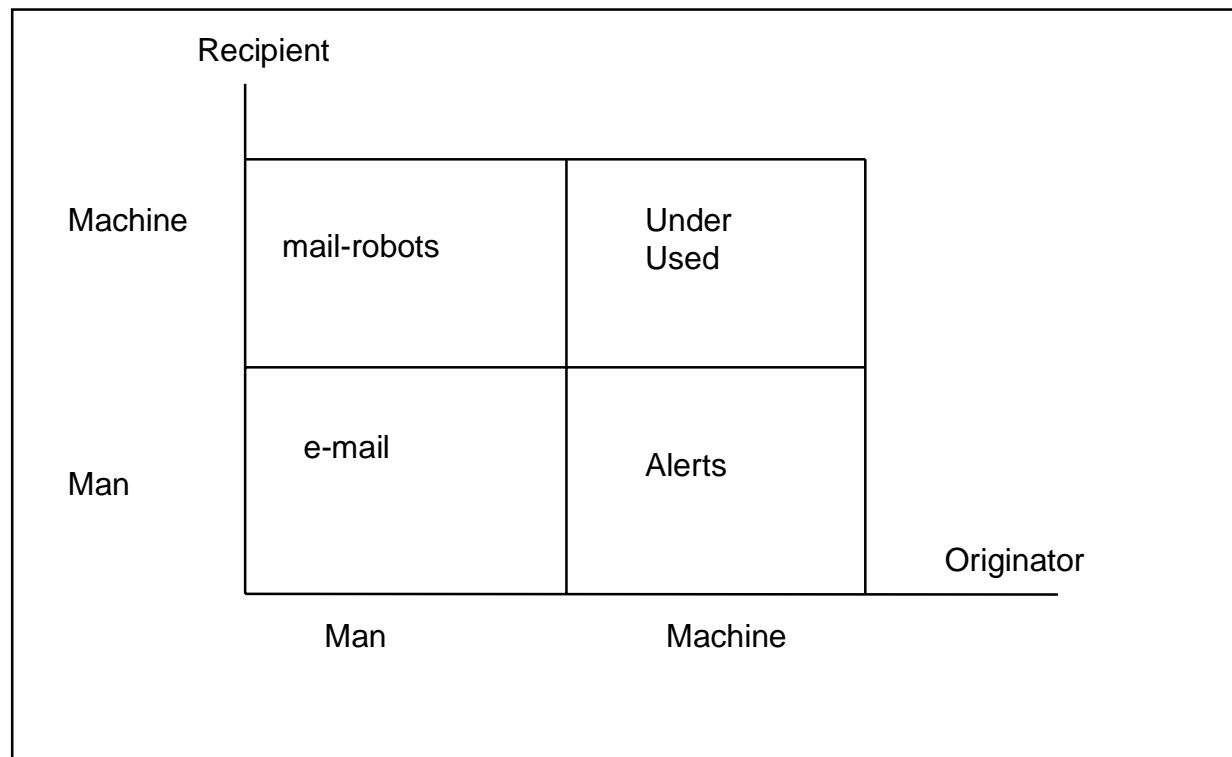

What and Why Dimensions of Messaging

- **What**

- Multi-Media (image, voice, ...)
- Application Specific Data
- Pointers to Information, ...

- **Why**

- Because the originator wants to send it.
- Because the recipient wants to receive it??
- Important
- Urgent

Outline

- **Current Landscape**
- **Basic Concepts & Terminology**
- **Internet E-Mail** 
- **Paging**
- **TeleCom / Cellular**
- **Ad-Hoc Packet Data**
- **EMSD**
- **Moving Forward**

Messaging Protocols vs. Supported Functions

Protocols Functions	SMTP	IMAP	POP	EMSD
Submission	XXX			XXX
Delivery	XXX			XXX
Relay (Routing)	XXX			
Retrieval		XXX	XXX	XX
Mailbox Access		XXX	X	
Mailbox Synchronization		XXX		

The number of “X”es in each box attempts to denote to what extent a particular function is supported by a particular protocol.

Messaging Communication Stack and Internet Email

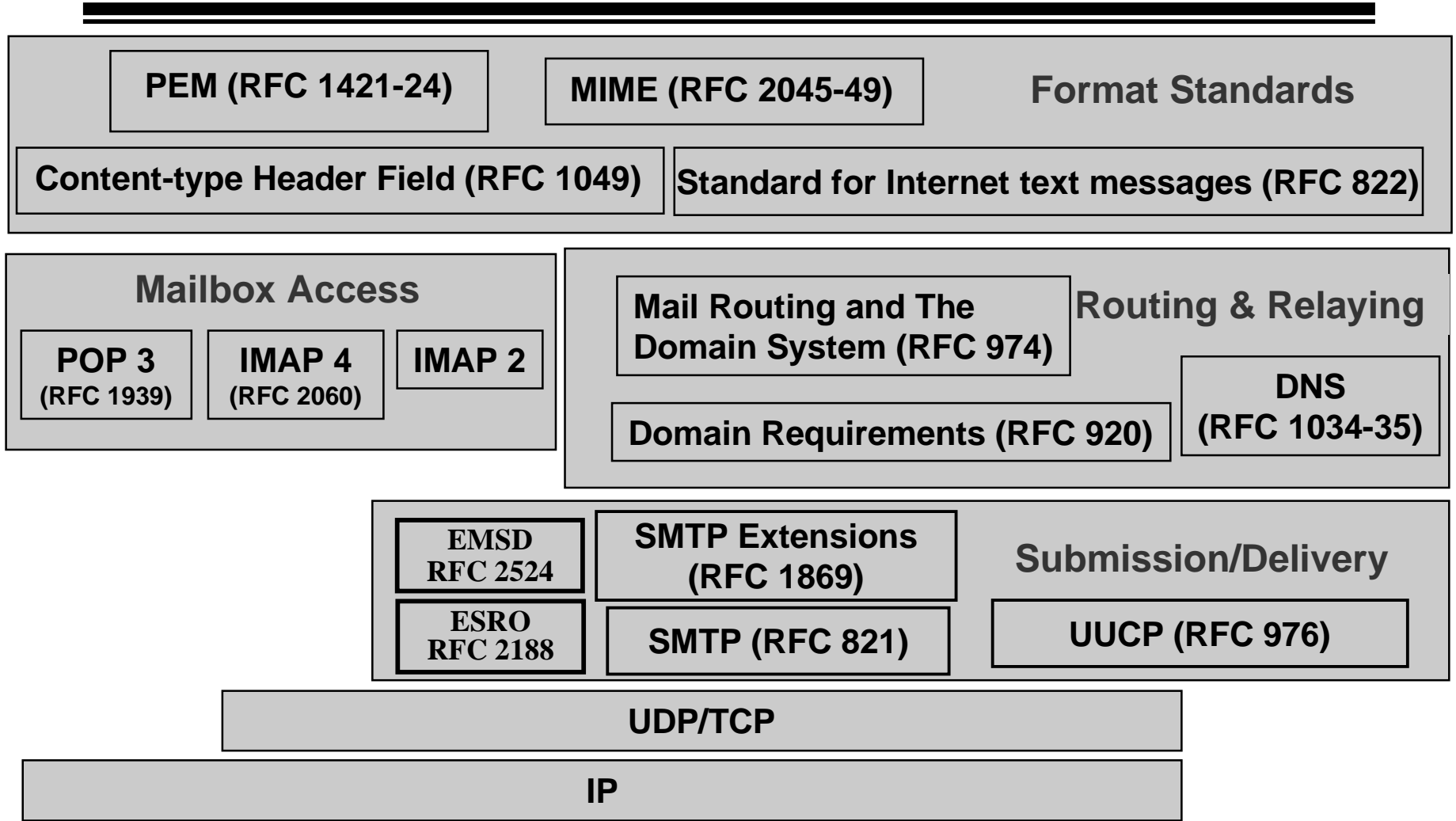

Anatomy of an Internet Mail Gateway

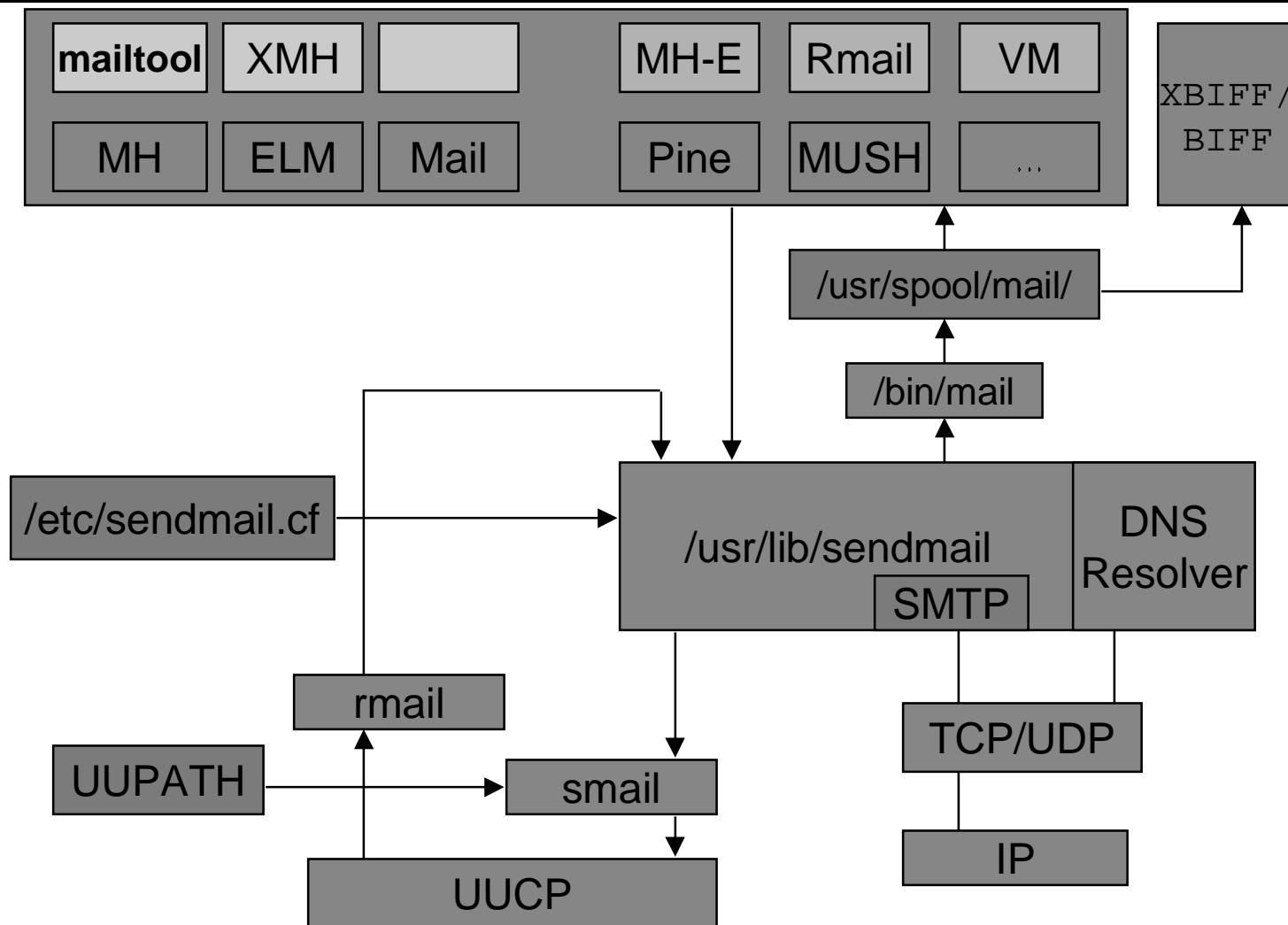

Outline

- **Current Landscape**
- **Basic Concepts & Terminology**
- **Internet E-Mail**
- **Paging** 
- **TeleCom / Cellular**
- **Ad-Hoc Packet Data**
- **EMSD**
- **Moving Forward**

One-Way Nationwide Paging

- **Systems does NOT know where the user is**
- **Broadcast page (message) nationwide**
- **Coverage is the best available of ANY wireless service**
- **Multiple input methods for contacting paging user**
 - Voice message
 - Voice-to-text by live operator
 - Touch-tone phone dial-in
 - Computer access

SkyTel 2-Way Best Use

- **Best suited for short messages/text only, no graphics**
 - To Pager: messages of up to 500 characters
 - From Pager: messages of up to 80 characters
- **Some pagers can be connected to computers via serial or IR links**
- **Pricing: (based on 10-character messages)**

Plan	Entry	1,000	1,500	2,000	5,000
Monthly:	\$24.95	\$29.95	\$39.95	\$49.95	\$99.95
Includes:	6,000 char	10,000	15,000	20,000	50,000
Overage:	\$0.10 per 10-character message for all plans				

Note: message is 1-way, response is a separate message__

Outline

- **Current Landscape**
- **Basic Concepts & Terminology**
- **Internet E-Mail**
- **Paging**
- **TeleCom / Cellular** 
- **Ad-Hoc Packet Data**
- **EMSD**
- **Moving Forward**

Digital Systems Today in U.S.

- **CDMA**
- **GSM**
- **iDEN (Nextel)**
- **TDMA**
- **IS-16 (OmniPoint)**

GSM

- **GSM**
 - nationwide if all systems built out (Chicago and Dallas missing today). Has become *de facto* standard in Europe
 - Used in Asia (excluding Japan)
 - Used as U.S. PCS Standard at 1900 MHz
 - GSM footprint in U.S. almost
- **GSM and PCS1900 are same standard -- different frequency band**
- **Based on TDMA technology**
- **Includes data-only channel for Short Message Service (SMS)**
- **Supports dial-up data at 9.6 Kbps today, going to 14.4 soon**
- **GSM plans to extend data rates to 28.8 Kbps and beyond, perhaps as high as 76.8 Kbps**

General Packet Radio Service (GPRS)

- **GPRS is high-speed packet data technology**
- **Developed for GSM systems**
- **It will increase data transmission speeds from the current 9.6 Kbps to over 100 Kbps**
- **Cost-effective to remain constantly connected**
- **No need to dial up a separate ISP**
- **Type of data capabilities planned for “third generation” cellular networks, but years ahead of them -- *according to GSM consortium***
- **Supports Internet Protocol (IP) and X.25 protocol**

iDEN / Nextel

- **Motorola - exclusive provider Nextel**
- **As deployed by Nextel, iDEN runs on SMR channels and, according to Nextel, its system covers approximately 70+% of the U.S. and growing**
- **iDEN is roughly based on TDMA technology with 6 communications paths per 25-KHz radio channel**
- **Nextel recently won additional spectrum at auction to expand its system**
- **Data support announcement expected shortly**

Outline

- **Current Landscape**
- **Basic Concepts & Terminology**
- **Internet E-Mail**
- **Paging**
- **TeleCom / Cellular**
- **Ad-Hoc Packet Data** 
- **EMSD**
- **Moving Forward**

Packet-Data Networks

- **American Mobile (was ARDIS)**
- **BellSouth Wireless Data (was RAM)**
- **Cellular Digital Packet Data (CDPD)**
- **Metricom**
- **...**

American Mobile Nationwide Data Network

- **Started as IBM / Motorola system designed for IBM service force**
- **Just purchased by American Mobile Satellite Corporation (AMSC) for \$120 Million**
- **Will be combined with satellite to cover entire U.S.**
- **System designed from beginning to provide good in-building coverage in key business areas of U.S.**
- **Data rates of 4-19.2 Kbps depending upon area**
- **Seamless nationwide roaming, no additional charges**
- **System “knows” where users are**

BellSouth Wireless Data (was RAM)

- **Now owned 100% by BellSouth**
- **Coverage about the same as American Mobile**
- **In-building coverage better than cellular**
- **System is 10-30 channels nationwide**
- **Battery power management included in network software (as with paging networks)**
- **Seamless, nationwide network**
- **Automatic roaming, no additional charges**
- **Network "knows" where user is located**

Cellular Digital Packet Data (CDPD)

- **Wireless Data Network Implemented as an Overlay on AMPS**
- **First Wide Area Wireless & Mobile Native IP Network**
- **Near Nationwide Coverage**
- **Data Rates of Below 19.2 Kbps**

Metricom

- **Not a Mobile Technology today --**
 - Wireline Replacement
- **Built out in Seattle, San Francisco Bay Area, and Washington, DC**
- **Ten airports built out**
- **Plans to build out nationwide**
- **25,000 users today**
- **Network looks like a phone line to the computer today**
- **Prediction: Passed its window of opportunity**

Wireless Knowledge Connections

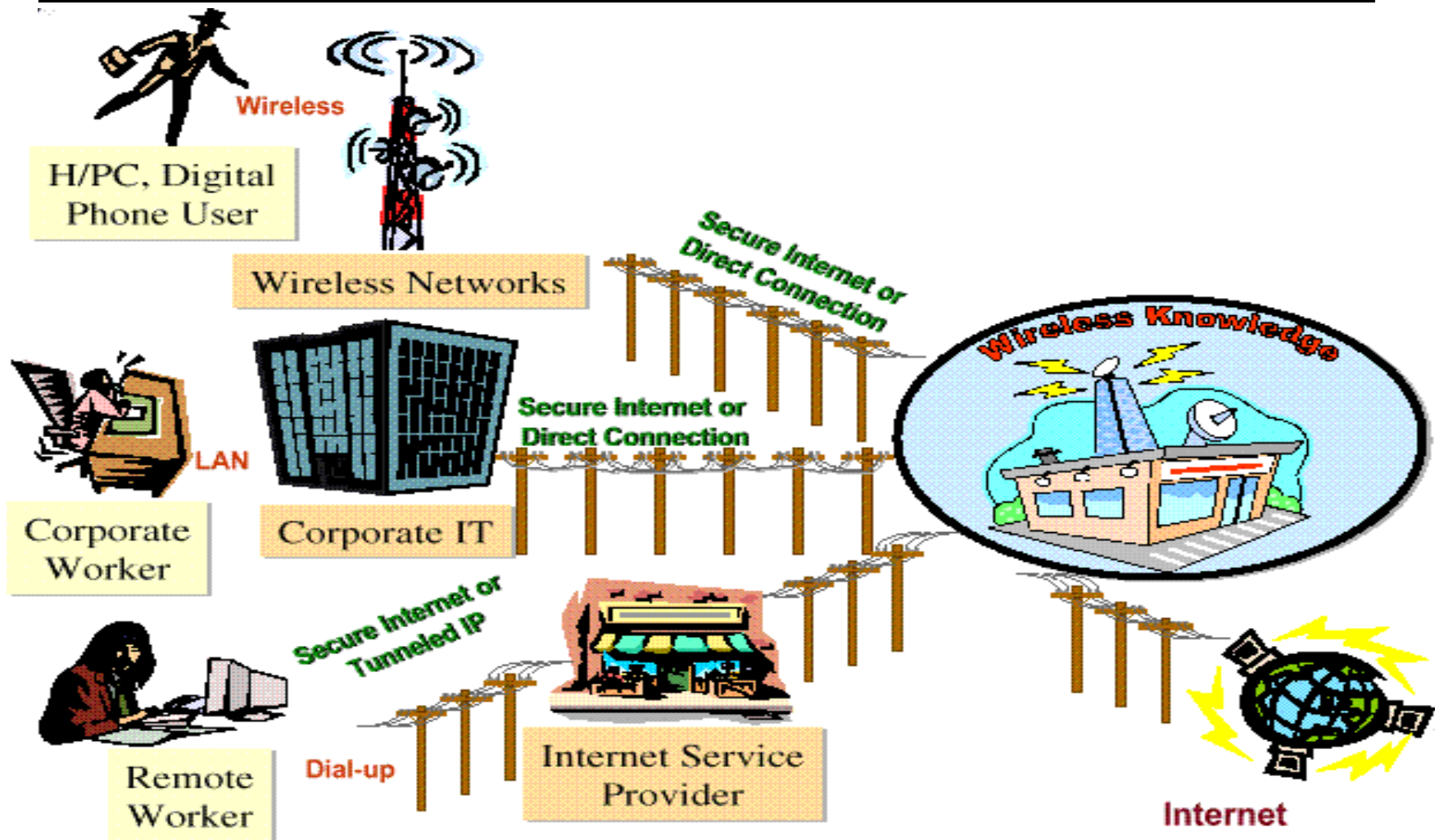

Blackberry Email Service

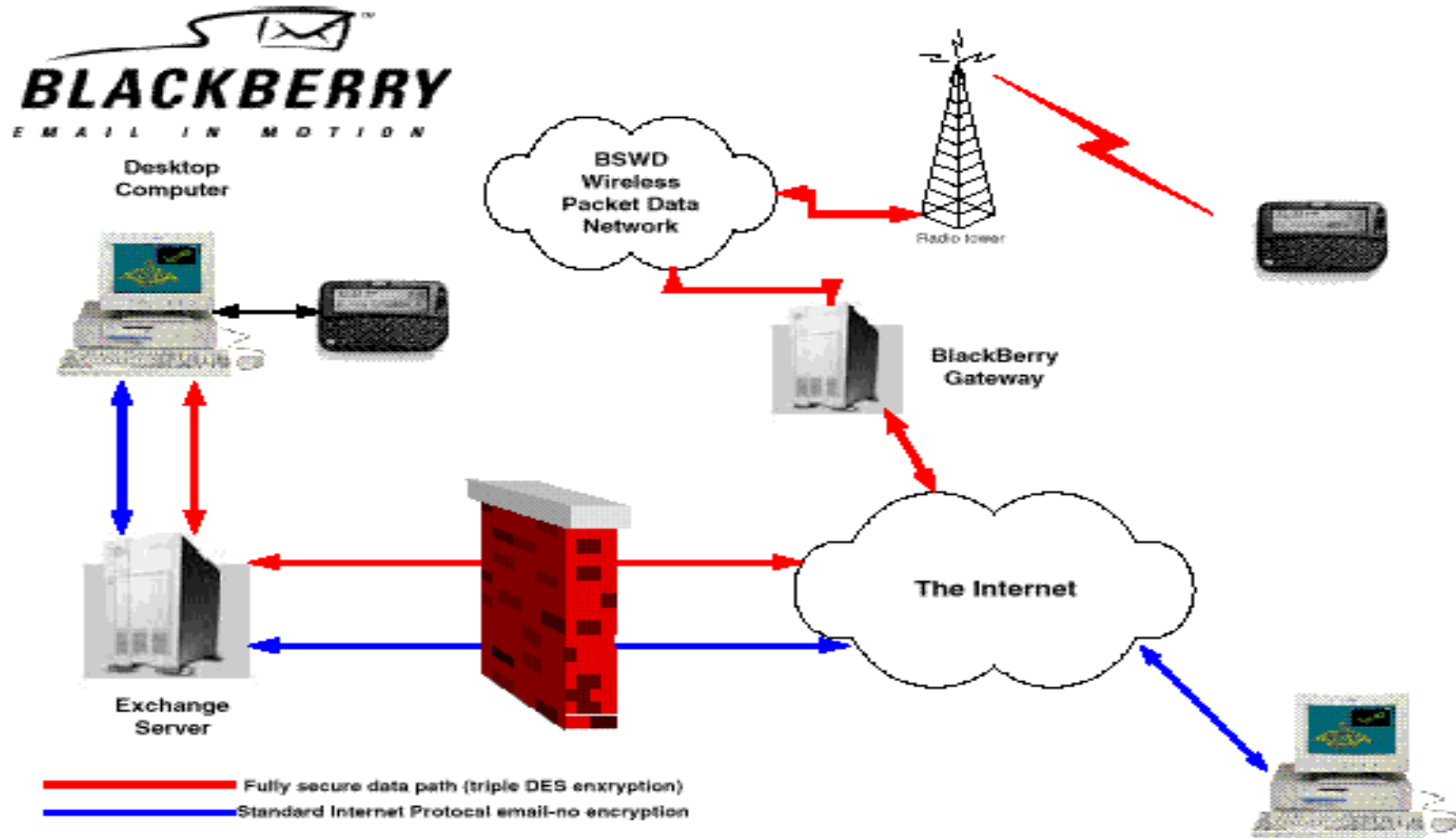

Palm VII System Architecture

- Increase Response Time
- Conserve bandwidth

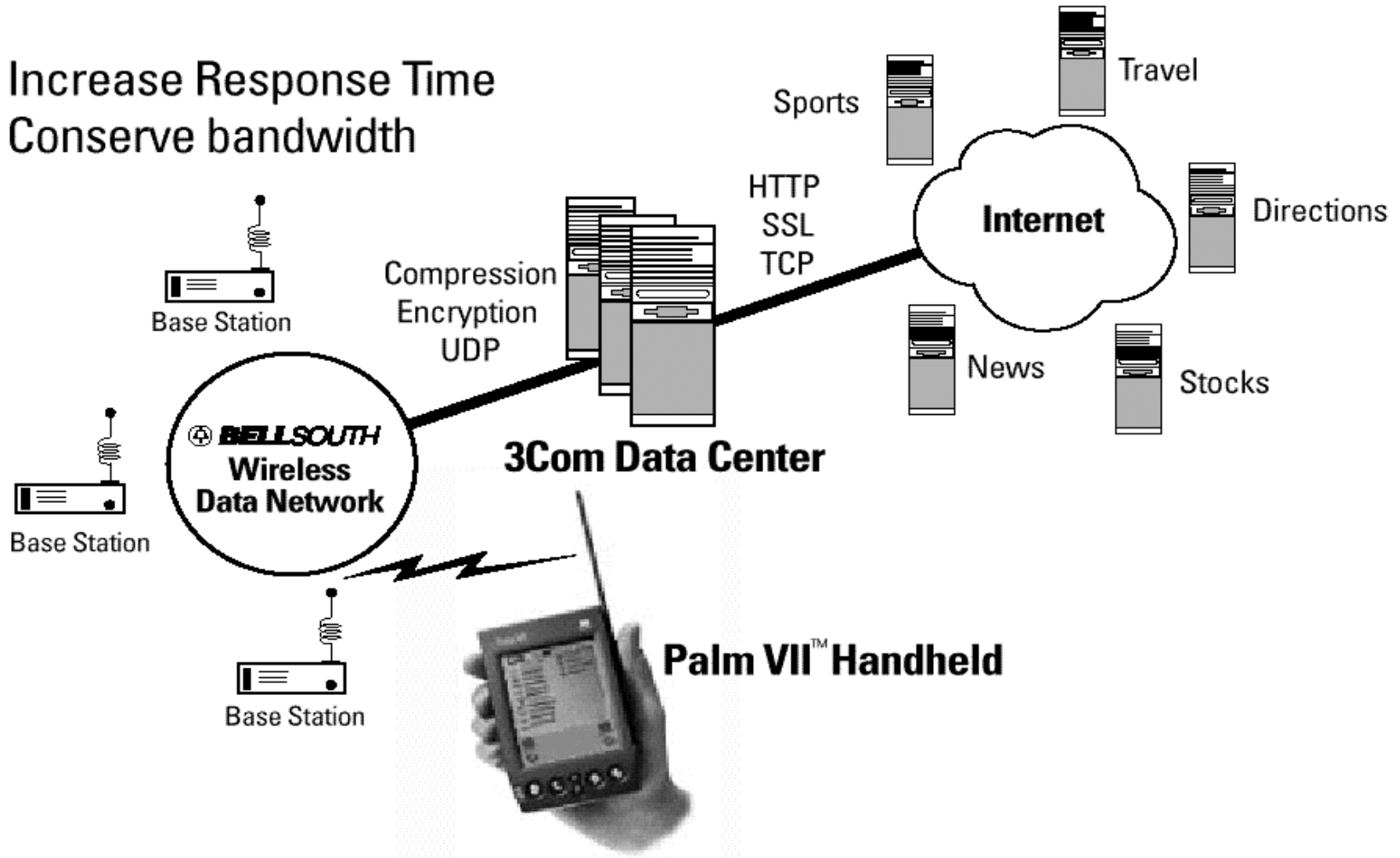

Outline

- **Current Landscape**
- **Basic Concepts & Terminology**
- **Internet E-Mail**
- **Paging**
- **TeleCom / Cellular**
- **Ad-Hoc Packet Data**
- **EMSD** 
- **Moving Forward**

It's A Mess Out There

- **Lots of “standards”**
 - Paging: one- way, one- and- a- half- way, two- way
 - Cellular: analog, CDPD, digital
 - PCS: CDMA, TDMA, GSM
 - Packet: Mobitex, RD- LAP, spread spectrum
 - Trunked radio: iDEN
 - Satellite: Big/ Little LEOS, geostationary
 - LMDS - Local Multipoint Distribution Service
- **Definitions are changing**
 - “Paging” (SMS) over digital cellular and PCS, and over (packet) BellSouth Wireless Data and American Mobile
 - Mobile communications is becoming a “platform” for applications
- **Changing definitions cause confusion, but create opportunities**

The New Environment

- **Internet is exploding**
 - Major applications are research, e- mail, news
 - Good applications for wireless use
 - The Internet is becoming extremely important for wireless communications
 - Major transport protocol for wireless
 - Intranets make systems integration easier
 - Can send messages via e- mail programs or Web sites
 - Wealth of data for wireless devices

The Concept of EMSD

- Lead towards the creation of

Open Mobile Messaging Industry

that quickly delivers the greatest benefits to the most users.

- Make the basis of Open Mobile Messaging Industry

Efficient Mail Submission and Delivery (EMSD) Protocols

Best Of Email + Best Of Paging

	Email	Traditional Paging (Today)	Open Mobile Msg. (EMSD)
Message Structures (From: , Subject: , Date:)	Yes	No	Yes
Mainstream & Open Any Device Works With Any Message Center	Yes	No	Yes
Intranet Provider Supplied Account (Generally)	Yes	No	Yes
Service Provider (ISP) Supplied Account	Yes	Yes	Yes
Mobile & Wearable	No	Yes	Yes
Urgent/Pushed Message Delivery	No	Yes	Yes
Access Through Ordinary Telephone	No	Yes	Yes
Good For Long Messages	Yes	No	No

Right Way Of Doing Open Mobile Messaging

- **Everybody and his cousin (and his cousin's cousin) is claiming to be doing two-way paging and wireless email over some Wireless Network.**
- **None of them is open and they do not interoperate.**
- **Very Bad For Everyone!**
- **We Say:**

**All Wireless-IP Based
Two-Way Pagers and Wireless-Email
Devices and Services Should
Interoperate**

Considering:

- that most wireless data networks shall converge toward being IP based;
- that Open Mobile Messaging is the main proven application in most wide-area wireless networks;
- that the Open Mobile Messaging industry and Internet Email industry can and should converge based on a set of open protocols that address the efficiency requirements adequately;
- that existing Internet email protocols are not bandwidth efficient;
- that existing Internet email protocols do not properly support the “push” model of delivery of urgent messages,

the EMSD protocol is designed to facilitate the convergence of IP based Open Mobile Messaging and Internet email.

Shaping The Future Of Open Mobile Messaging Industry

- **This is about:**

“Building Of the Open Mobile Messaging Industry”

- **This is:**
 - Not just about a niche market
 - Not just about a product or products
 - Not just about a “Paging Services”
 - Not just about standards & technology

An Industry means all of the above and more...

From a General Vision:

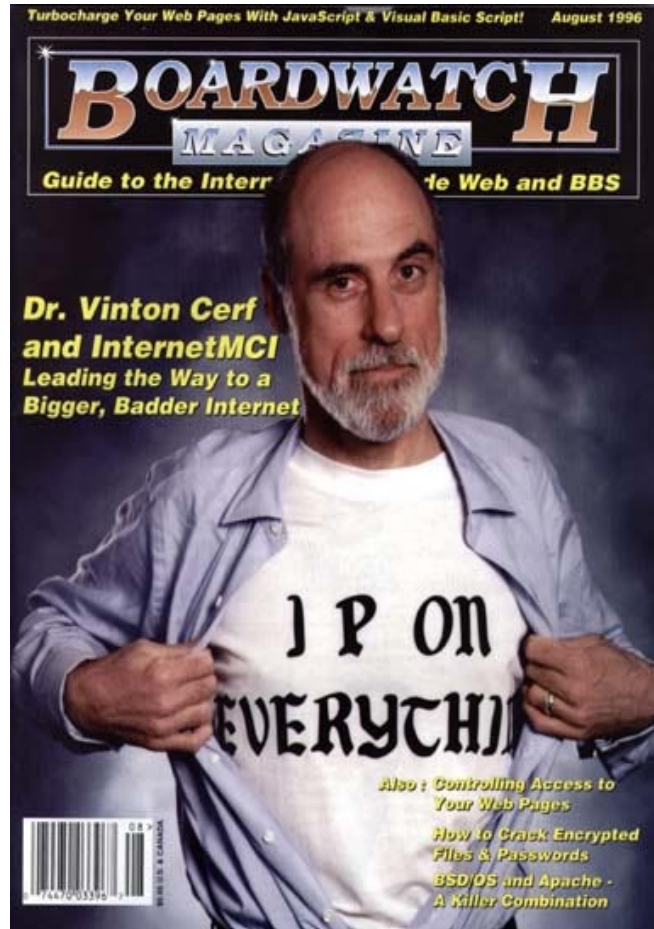

- IP on Everything

To a Specific Vision:

EMSD on All Two-Way Pagers Everywhere

- **What is Efficient Mail Submission and Deliver (EMSD) Protocol?**

Shaping The Future Of Open Mobile Messaging Industry

- **Building a Network Related Industry involves:**
 - The recognition that: “the network grows through openness & collaboration, NOT through competition & confrontation”
 - The “medium” is tricky.
- **Focus on Widespread Deployment & Usage.**
- **True belief in Openness.**
- **Building an Industry involves giving away a lot for free.**

Existing Initiatives Don't Meet The Requirements

- **PAGING**
 - Existing Two-Way Paging Systems (e.g., ReFlex) don't fit right with Internet E-Mail and are too limited (No native To, CC, From, ...);
- **CELLULAR**
 - Existing Tele-Comm Based Systems (e.g., SMS) are out of sync with Internet E-Mail and are too limited;
- **PACKET DATA**
 - Existing Packet Data Mobile Messaging Solutions do not work together and do not build on each other's assets (palm.net, wireless knowledge, blackberry);
- **INTERNET**
 - Existing Internet Protocols are not bandwidth efficient and do not properly support the “push” model of delivery of urgent and important messages;

These worlds co-exist today through e-mail gateways.

Gateways result in loss of information.

GATEWAYS ARE BAD!

Open Mobile Messaging Industry

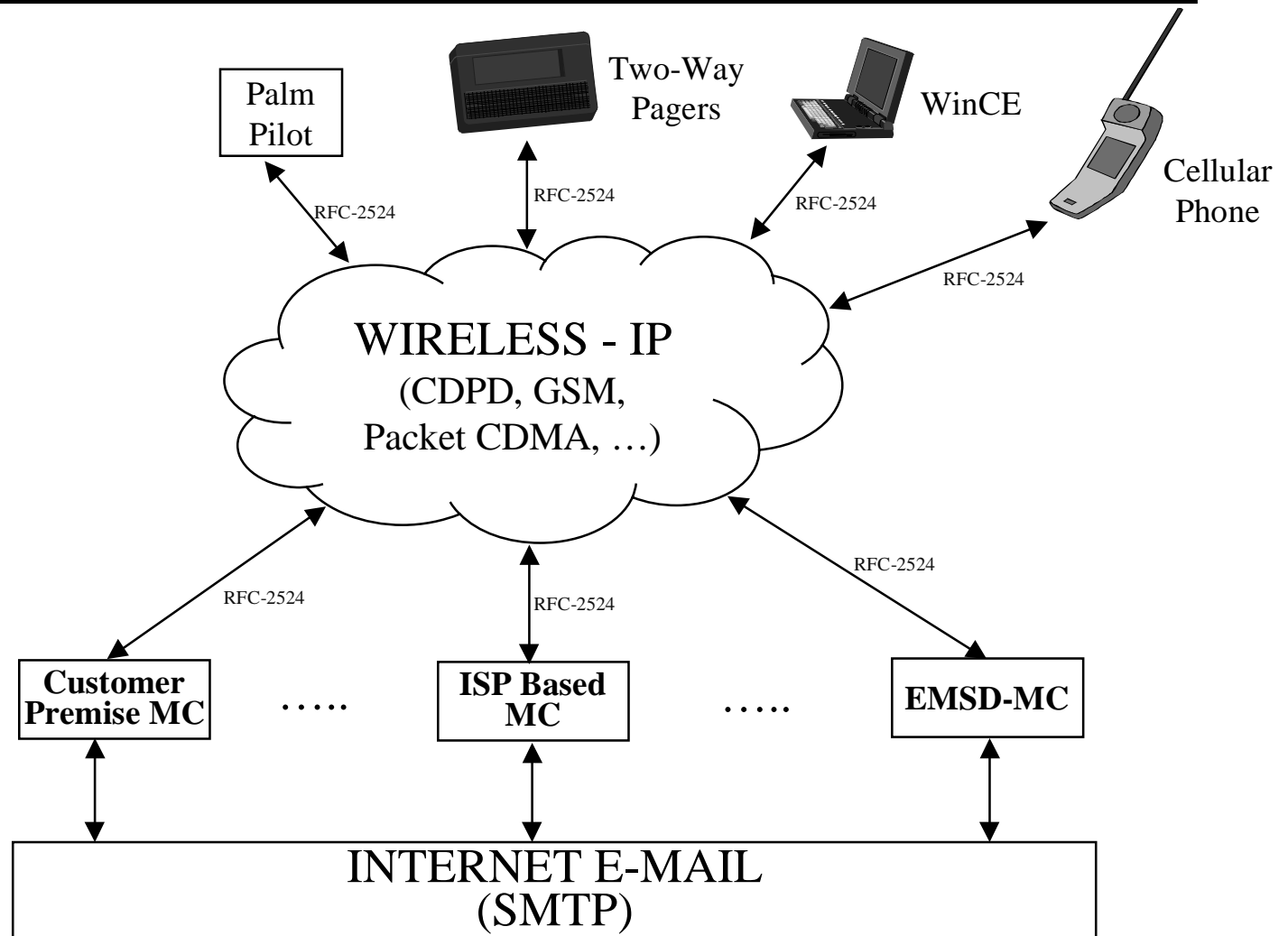

Advantages Of Moving Towards The Open Mobile Messaging Industry

- **The reality of Wireless-IP is accepted & exploited;**
- **Best of breed devices interoperate with best of breed message centers;**
- **User, Consumer & Goodness centric -- Not vendor and operator centric.**

Users are not tied to the service providers and continue to use their devices even after changing services;

- **Allows for two-way paging and Internet Email to truly converge;**
- **Exact same set of messaging capabilities and software can be used across a variety of wireless networks and technologies;**
- **Longer battery life, less latency, cheaper network usage, more network capacity;**
- **Competition results into better devices and better services -- economies of scale kick in, big time.**

Remote E-Mail Access Using EMSDP Client

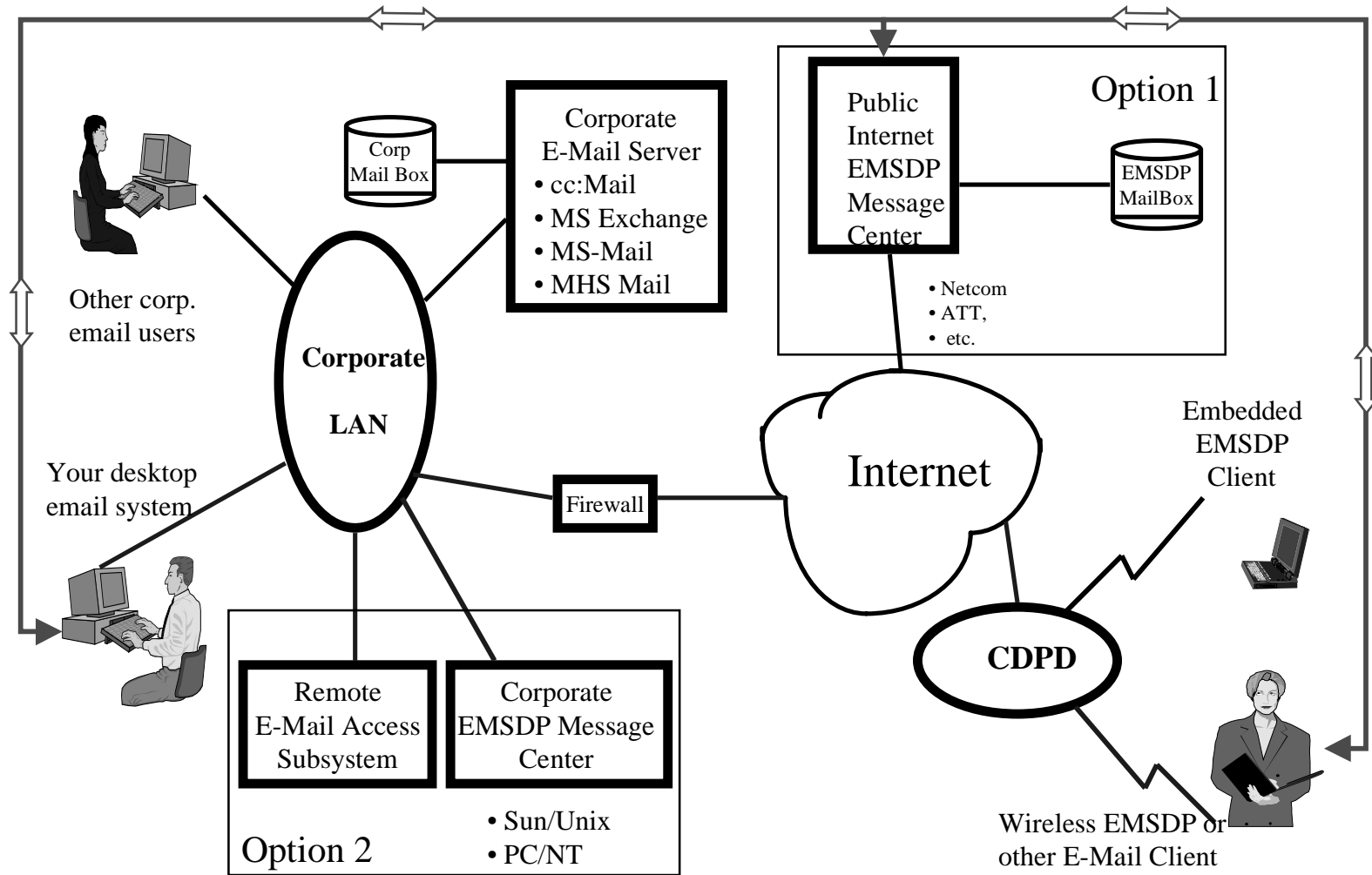

Integrated Demo Scenarios

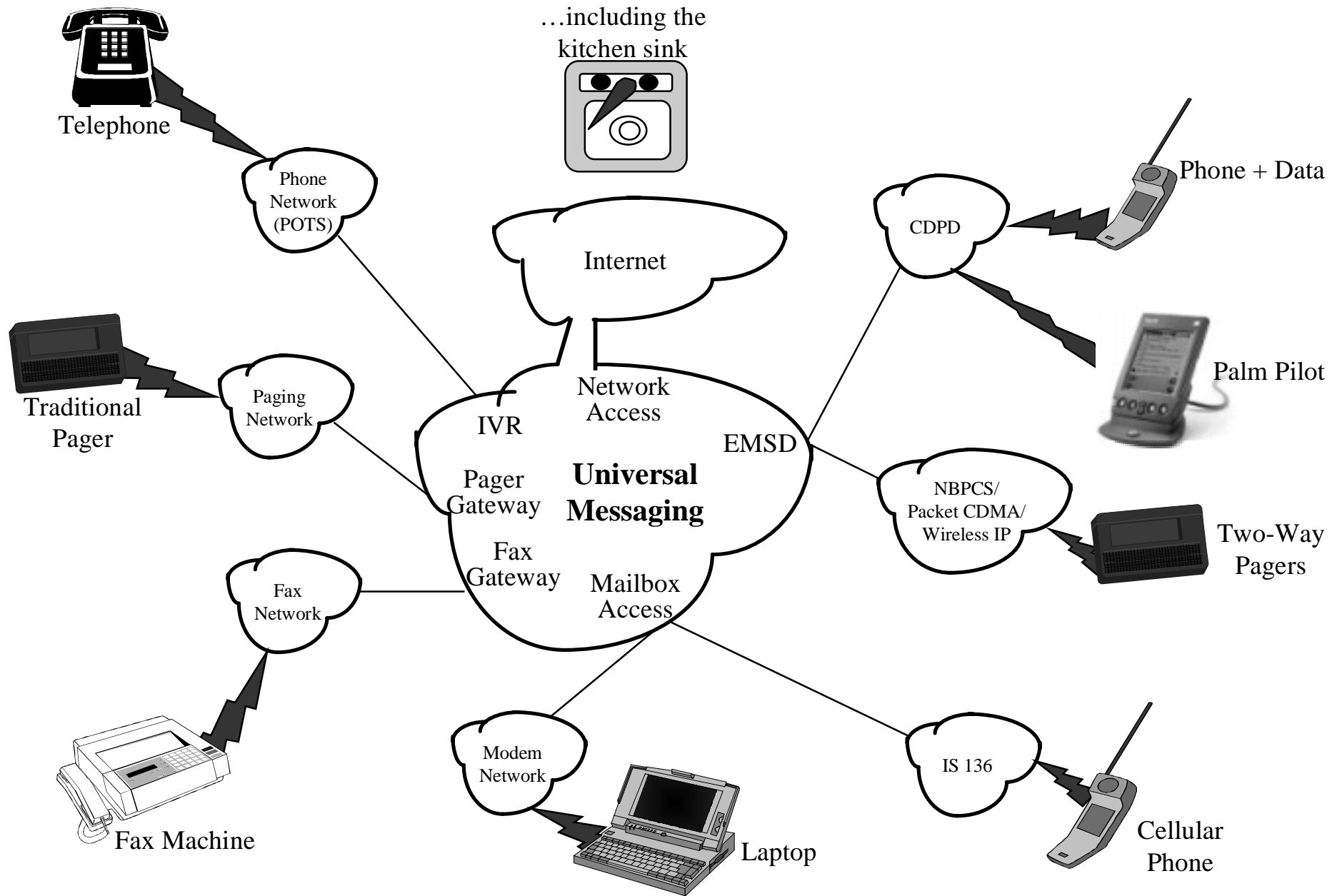

Check List For Success

- **Pre-Requisite (External):**

- Reasonable Wireless Networks (Reliable, Widespread, Affordable)
- Reasonable Wireless Modems (Affordable, Good Form Factors)
- Reasonable Devices (Palm Pilot, WinCE, Pagers, Cell Phones,...)

	<input checked="" type="checkbox"/>
<input checked="" type="checkbox"/>	
	<input checked="" type="checkbox"/>
<input checked="" type="checkbox"/>	
<input checked="" type="checkbox"/>	

Beta *Shipping*

- **Requirements (Controllable):**

- Open Protocols & Standards
- Widespread Two-Way Paging Subscriber Services
- Device Software Products (For: Palm Pilot, WinCE, Pagers, ...)
- Intranet (Customer Premise) Message Center Software Products
- ISP Message Center Products

Wireless Networks, Modems & PDA's

Wireless Networks:

- CDPD
- GSM
- Packet CDMA
- Mobile IP
- TDMA

Modems:

- Sierra Wireless
- Motorola
- Mitsubishi
- ...

PDA's:

- Win CE
- Palm Pilot
- Symbian
- ...

Protocols & Standards

- **Can't Build Such An Industry Without OPEN Protocols**
- **The Right Protocols should:**
 - Fit Right & Play Well with the rest of Internet Messaging Environment
 - Address Most Of The Relevant Requirements
 - Be Completely Open. NO IPRs, NO Copying Restrictions
 - Be widely published & easily accessible To Everyone
 - Be widely reviewed & be subject to widely scrutiny
 - Have an Organization to maintain & enhance them

Requirement for EMSD

- **Be an extension of the existing messaging world (e-mail centric).**
- **Highly optimized for Short Messages.**
- **Capable of accommodating varying size messages.**
- **Band width efficient (compact headers ...).**
- **Power efficient (respect for Battery).**
- **Respect for mobile's resources (Client-Lite & Server-Heavy).**
- **Highly extendible (Layers with options and extensions).**
- **Secure.**

EMSD Protocols as the Foundation of Mobile Messaging Industry

- **Can't Build Such An Industry Without OPEN Protocols**

- AT&T/Neda's Efficient Short Remote Operations (ESRO) Protocol Specifications -- RFC-2188

Published: September 1997

Author : M. Banan, Neda
M. Taylor, AWS
J. Cheng, AWS

- Neda's Efficient Mail Submission and Delivery (EMSD) Protocol Specification -- RFC-2524

Published: February 1999

Author: M. Banan, Neda

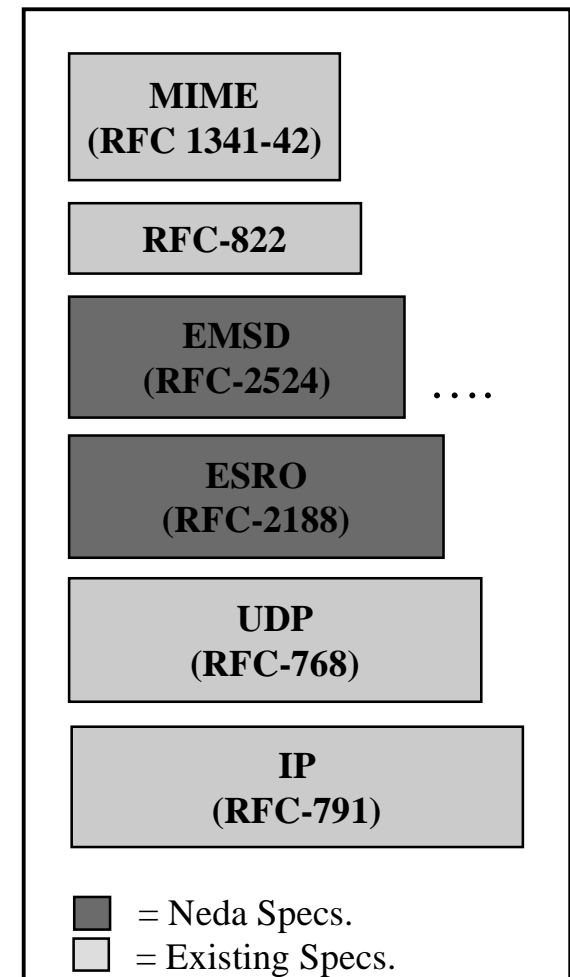

EMSDP is Very Efficient

- **Next few charts compare message submission using SMTP and EMSDP:**
 - Same brief message is submitted from the user using all protocols under comparison
 - Same brief message is delivered to the user using all protocols under comparison

Comparison of SMTP and EMSD Efficiency

	SMTP	SMTP+ Pipelining	QMTP, QMQP	EMSD
client	SYN	SYN	SYN	Submit Req
server	SYN ok	SYN ok	SYN	Submit Resp
client	HELO	HELO	message	ack
server	ok	PIPELINING	accept close	
client	MAIL	MAIL RCPT DATA	close	
server	ok	ok		
client	RCPT	message QUIT		
server	ok	accept ok close		
client	DATA	close		
server	ok			
client	message			
server	accept			
client	QUIT			
server	ok close			
client	close			

EMSDP Delivery vs. Other Protocols

	EMSDP	SMTP	IMAP	POP
Total number of IP packets	3	24	36	34
Total IP bytes	387	1778	3593	2731
Total MSG length (mail hdr+ mail body) (bytes)	299	301	833	561
Total overhead (bytes)	88	1477	2760	2170

SMTP Submission Trace

IP_PDU	MailServer	UA	DATA	TCP	IP	subtotal
1	TCP .<----- TCP SYN ----- .	0		24	44	
2	TCP . ----- TCP SYN ack ---->.	0		24	44	
3	TCP .<----- Push ACK ----- .	0		20	40	(128)
4	SMTP . ----220 server ready --->.	116		136	156	
5	TCP .<----- Push ACK ----- .	0		20	40	(196)
6	SMTP .<----- HELO <client>--- .	36		56	76	
7	SMTP . ----250 server Hello --->.	111		131	151	
8	TCP .<----- Push ACK ----- .	0		20	40	(267)
9	SMTP .<--MAIL FROM:<sender> --- .	32		52	72	
10	SMTP . ----250 ... Sender ok--->.	39		59	79	
11	TCP .<----- Push ACK ----- .	0		20	40	(191)
12	SMTP .<--RCPT TO:<rcpt>----- .	33		53	73	
13	SMTP .<----250...Recipient ok-- .	45		65	85	
14	TCP .<----- Push ACK ----- .	0		20	40	(198)

SMTP Trace (continued)

IP_PDU	MailServer	UA	DATA	TCP	IP	subtotal
15	SMTP .<----- "DATA" ----- .		6	26	46	
16	TCP . ----- ACK ----->.		0	20	40	(86)
17	SMTP . ----354..end with "."---->.		50	70	90	
18	TCP .<----- Push ACK ----- .		0	20	40	(130)
19	SMTP .<--Mail header+body ----- .		437	457	477	
20	SMTP .<----- . ----- .		5	25	45	
21	TCP . ----- ACK ----->.		0	20	40	(562)
22	SMTP . ----- 250 Ok ----->.		8	28	48	
23	TCP .<----- Push ACK ----- .		0	20	40	
24	TCP .<----- Push Reset ----- .		0	20	40	(128)

EMSDP Message Submission Trace

SUBMISSION

IP_PDU	MailServer	UA	DATA	UDP	IP
1	UDP	.<---Invoke header+body --- .	206	214	234
2	UDP	. -----Response ----->.	15	23	43
3	UDP	.<----- Ack ----- .	2	10	30

EMSDP Message Submission vs. SMTP

	EMSDP	SMTP
Total number of IP packets	3	24
Total IP bytes	307	1886
Total MSG length (mail hdr+ mail body) (bytes)	206	437
Total overhead (bytes)	101	1449

EMSDP Delivery Trace

DELIVERY

IP_PDU	UA	MailServer DATA	UDP	IP	
1	UDP	.<---Invoke header+body --- .	299	307	327
2	UDP	. -----Response ----->.	2	10	30
3	UDP	.<----- Ack ----- .	2	10	30

EMSDP Delivery vs. Other Protocols

	EMSDP	SMTP	IMAP	POP
Total number of IP packets	3	24	36	34
Total IP bytes	387	1778	3593	2731
Total MSG length (mail hdr+ mail body) (bytes)	299	301	833	561
Total overhead (bytes)	88	1477	2760	2170

Efficiency, Efficiency, Efficiency

Delivery: EMSD, SMTP, IMAP, POP

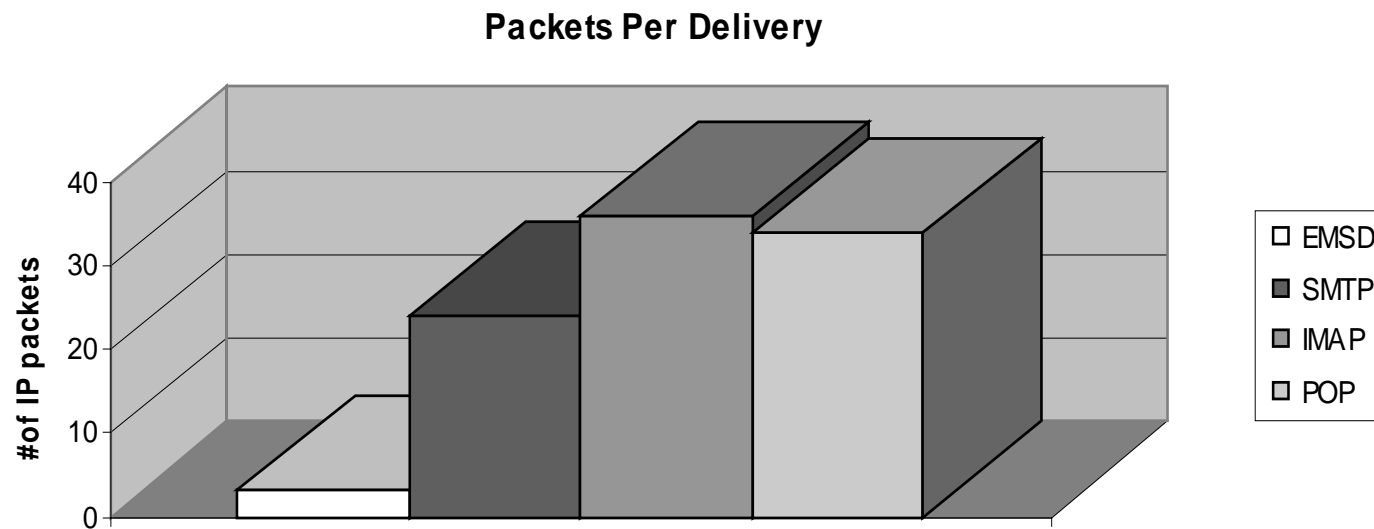

Bandwidth Efficiency Means:

- More Capacity
- Longer Battery Life
- Cheaper Network Usage
- Less Latency

Performance Conclusions

EMSDP is up to 10+ times more efficient than other messaging protocols in submitting and delivering messages.

Standards & Technology Released To The Market To Accomplish Leadership

WWW.EMSD.ORG

WWW.ESRO.ORG

- **A vehicle for promotion of EMSD vision of Two-Way Paging Industry.**
- **A means for maintenance & enhancements of EMSD Protocols**
- **A non-Neda specific way of promoting EMSD Protocols**
- **A way of expanding the market based on our protocols**

EMSD.ORG Road Map

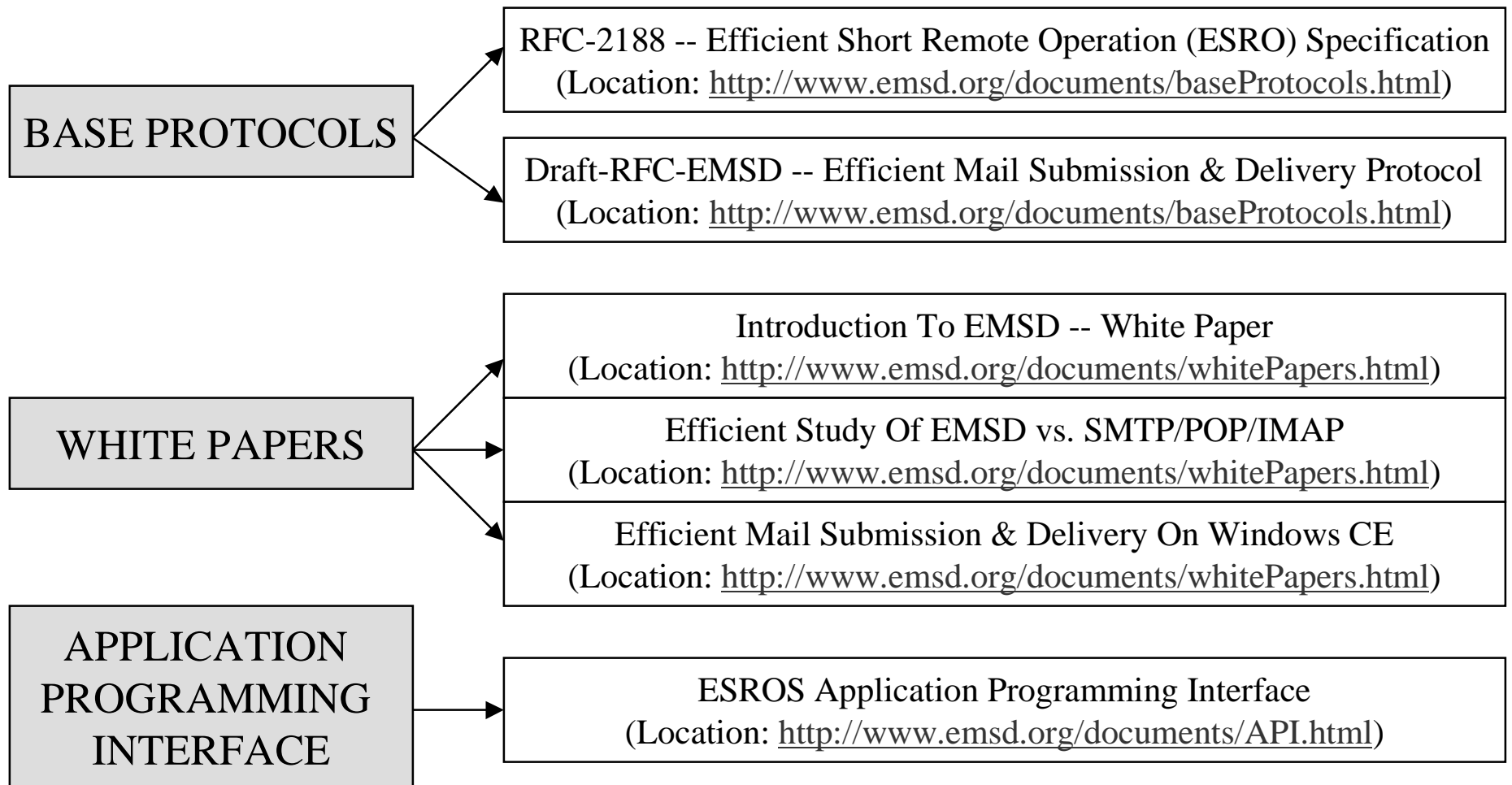

Models & Precedence

	Web Industry	Mobile Messaging Industry
Pre-Requisite	Wired IP Networks, Multimedia PCs	Wireless IP Networks, Palm Top PCs, ...
Open Standards	HTTP/HTML published as RFC-1945 & RFC-1866	ESRO/EMSD published as RFC-2188 & RFC-2524
Standards Organization	W3 Consortium	EMSD.ORG
Client Software	Browser on all platforms freely available	User Agent Software for Windows CE .. Freely available
Server Software	Plug & Play, Freely available	Plug & Play, Reasonable Licensing
Service Providers	mosaic.com, ...	PagingMail.net, ...
Non Business Thinking	Cern Physics Lab Guys	Mohsen
Business Leadership	Netscape	NEDA
Open Source	Apache, Netscape	Ready For Open source

Market Segments

- **User Market Segments**
 - Start with Vertical Markets, move towards Horizontal Markets
- **Message Center Market Segments**
 - Wireless-Data / Paging Operators (AT&T, GTE, ...)
 - ISPs (UUNET, Netcom, PSI, ...)
 - Intranets (Boeing, Virginia Mason Hospital, ...)
- **Device Market Segments**
 - Phone Manufacturers, Pager Manufacturers
 - Modem Manufacturers, PDA manufacturers.
- **Technology Market Segments**
 - System Integrators

End Users Market Segments

Starting Vertical - Ending Horizontal

- **Medical Industry**
- **Public Safety**
- **Emergency Professionals**
- **Drug Dealers**
- **Field Service**
- **Financial Industry**
- **...**
- **Mobile Professionals**
- **Apartment Managers**
- **Expecting Fathers**
- **Rich Brats (90210)**
- **Soccer Moms**
- **...**

Customers of Mail Server Products

	<u>PUBLIC</u> (ISPs)	<u>PRIVATE</u> (Corp. Intranet)	<u>PERSONAL</u> (Desktop)
Customers	Wireless-Data Providers, Paging Operators, ISPs, ...	Intranet Messaging Operators Fortune 5000	Desktop Users
Product Description	Message Center for ISPs, ...	Message Center for Intranets	Personal Desktop Forwarders
Typical Customers	AT&T, GTE, PSI, UUNET, Netcom, ...	Boeing, Virginia Mason Hospital, ...	YOU
Key Attributes	Manageability, Scalability, Reliability	Ease of use, plug-and-play, Corporate control	Ease of use, plug-and-play, Personal control
Analogy	Phone company provided Voice Mail (OCTEL, ...)	Corporate provided Voice Mail (Active Voice, ...)	Personally controlled Voice Mail (Answering Machine, ...)

Device Side Seeding Strategy

- **GOALS**

- Make use of EMSD widespread on **ALL** general purpose **Palmtops, PDAs & Laptops.**
- Ensure Interoperability through control and maintenance of a **single source base.**

- **STRATEGY**

- For General Purpose Computers & Devices (Palm Pilot, WinCE, EPOC)
 - The EMSD-UA source code is made **Open Source** and is subject to Gnu Public License (GPL).
- For Dedicated Devices (Pagers, Cell Phones, Modems)
 - The EMSD-UA source code is subject to a one time very reasonable price per product & per subnetwork technology license. Plus a per year maintenance fee.

FOCUS

- Put It On The **PDA**
- Put It On The **PHONE**
- Put It On The **PAGER**
- Put It On The **MODEM**

Put It On The Phone/Modem/Pager

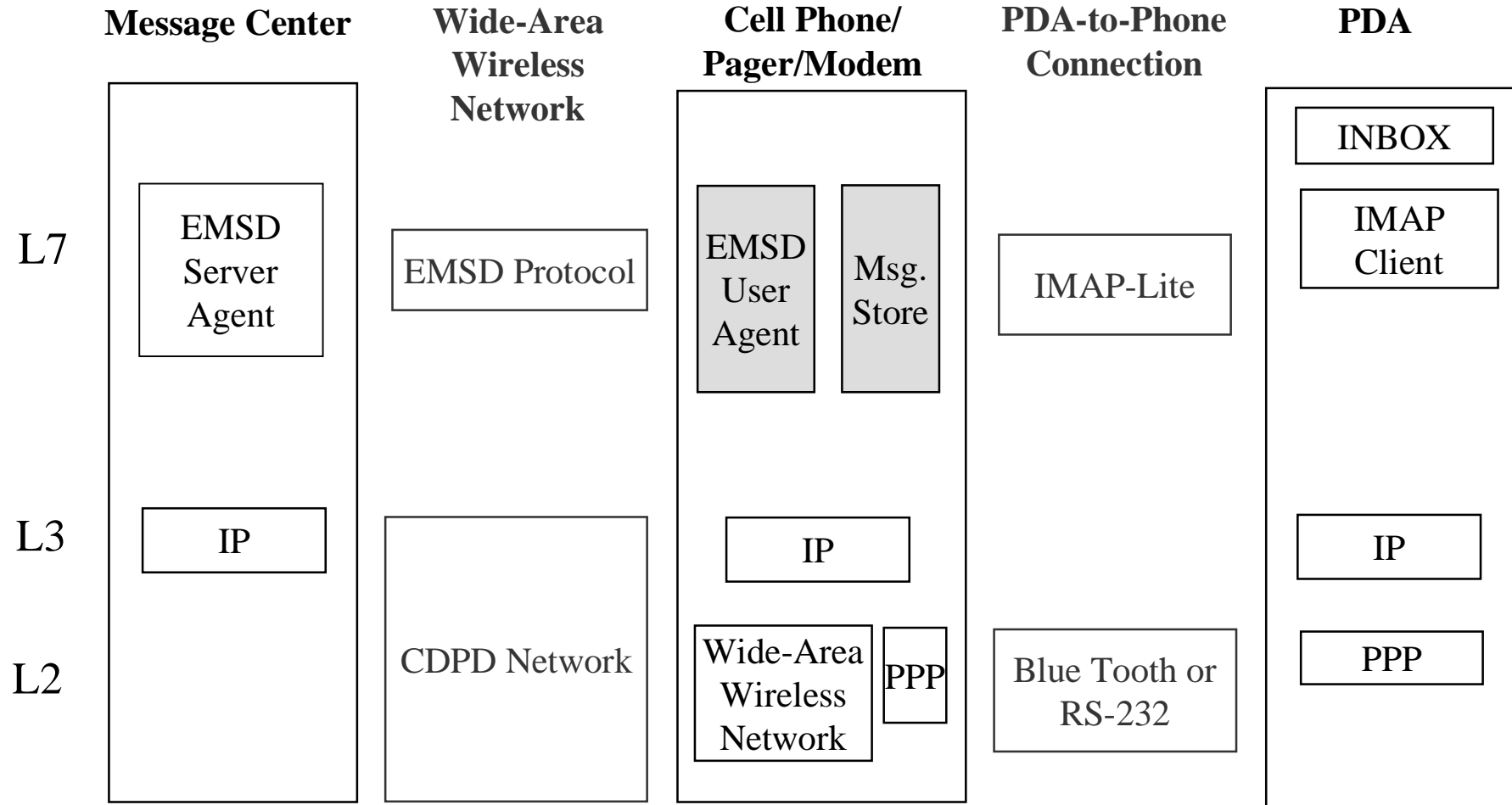

EMSD on Win/CE: Details

Windows CE Palmtop Version of Neda Palmware EMSD

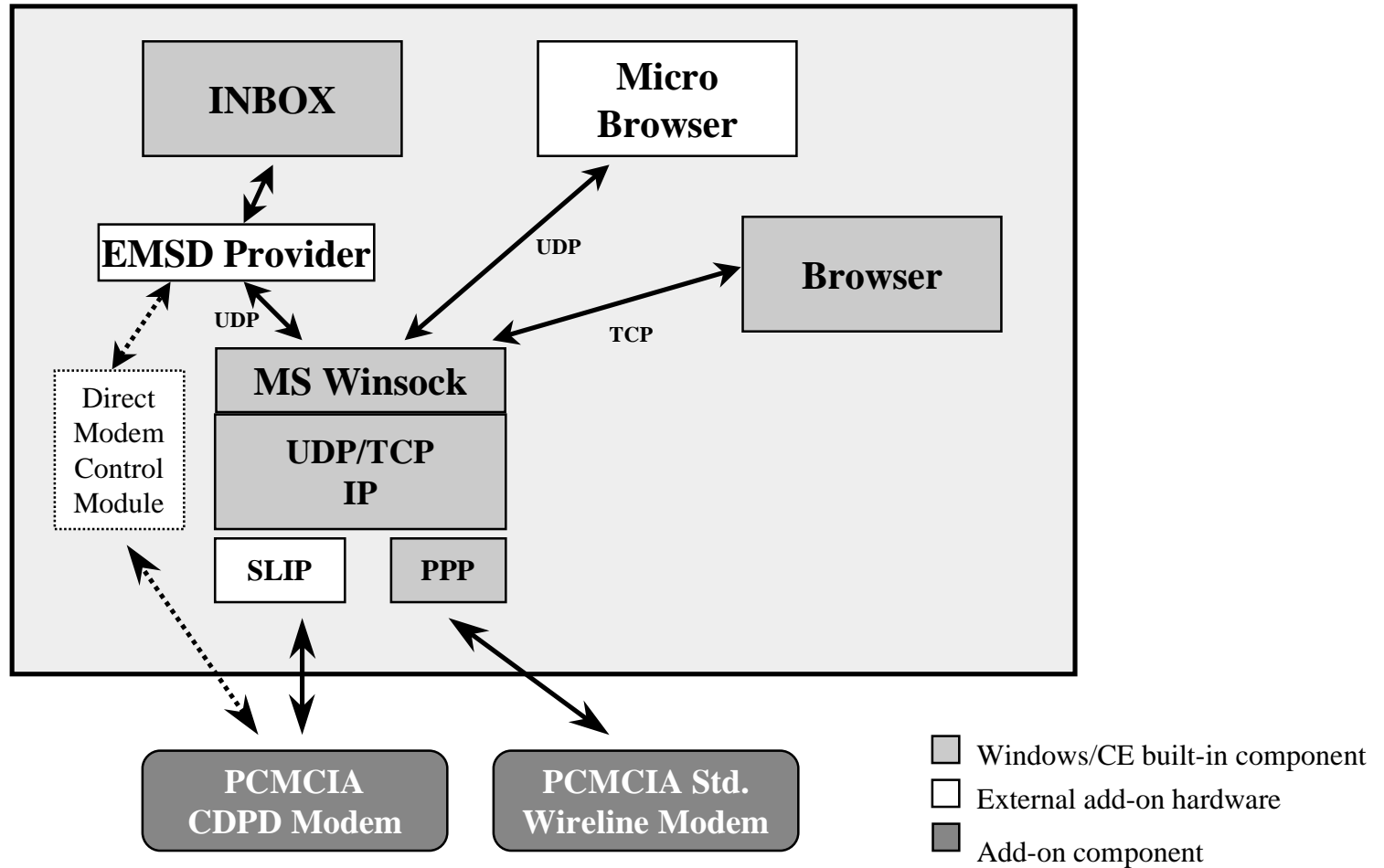

Competition Is Good !!!

	Before 200x	After 200x
Offerings	Short Term Suppliers	Long Term Suppliers
Reasonable Wireless Networks (IP Based)	CDPD, GSM, ...	Wireless & Mobile-IP
Wireless Modem	Sierra, Motorola, ...	Best Of Breed
PDA's & Palm Tops	WinCE, Palm Pilot, ...	Best Of Breed
Protocols & Standards	EMSD.ORG (NEDA)	IETF, ...
Device (Client) Software Products	NEDA	Best Of Breed
Subscriber Services	PagingMail.net (NEDA)	Best Of Breed
Customer Premise Message Center Products	NEDA	NEDA + Best Of Breed
ISP Message Center Products	NEDA	NEDA + Best Of Breed
Protocol Technology	NEDA	NEDA + ...
Rule Based Message Processing	Demo Capability	Best Of Breed
INBOX Synchronization	Demo Capability	Best Of Breed

All That Is Needed IS READY

- **Standards & Technology**
<http://www.emsd.org> (EMSD)
<http://www.esro.org> (ESRO)
- **Message Center Products (Server Software)**
<http://www.neda.com>
- **Device Products (Client Software)**
<http://www.neda.com>
- **Subscriber Services**
<http://www.subscribers.neda.com>
<http://www.ByNumber.com>
etwp.com, PagingMail.net, ByName.com

Complete, Ready, Available, Free,

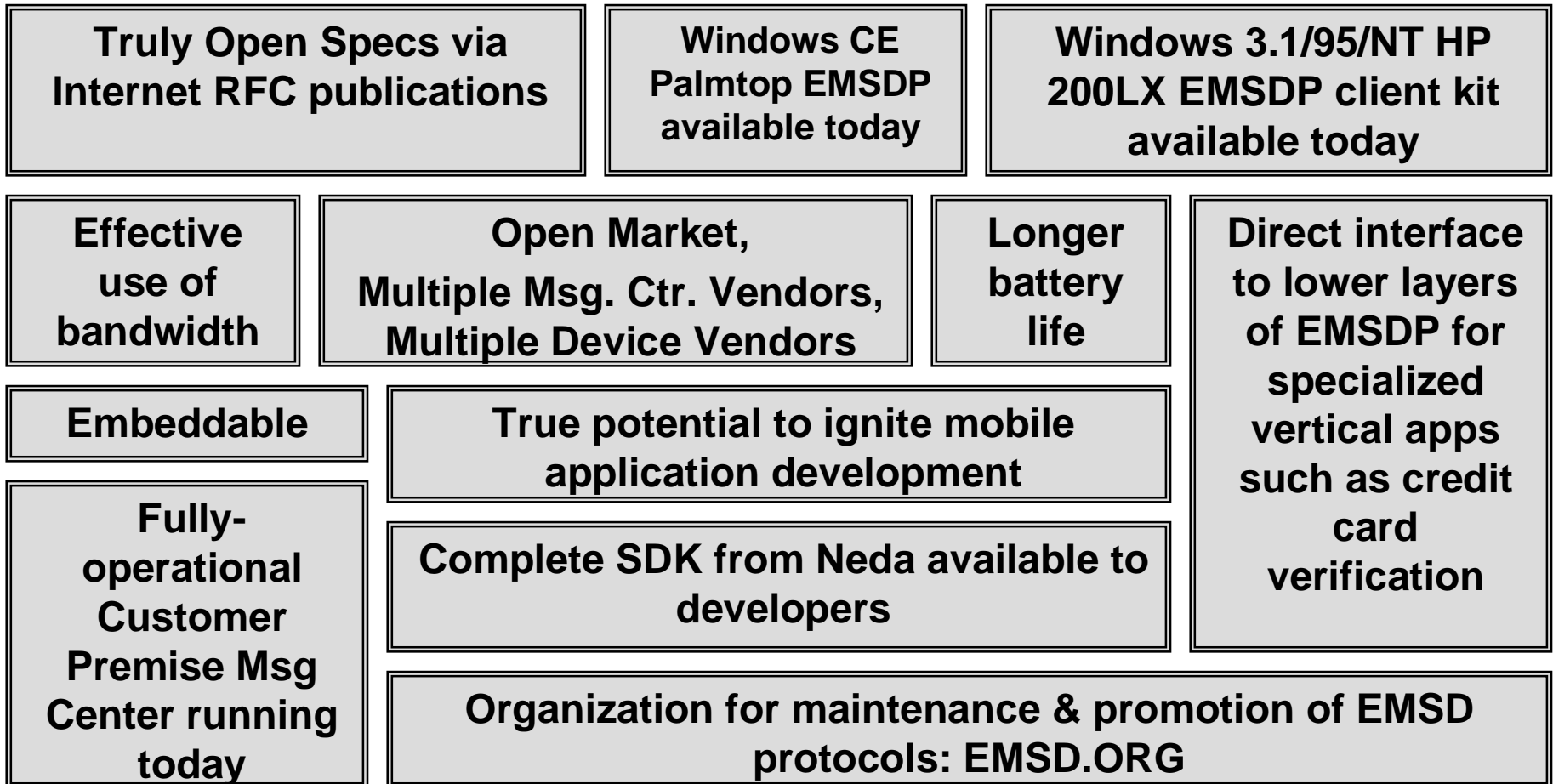

Outline

- **Current Landscape**
- **Basic Concepts & Terminology**
- **Internet E-Mail**
- **Paging**
- **TeleCom / Cellular**
- **Ad-Hoc Packet Data**
- **EMSD**
- **Moving Forward** 

Wireless Data In Vertical Markets Has
Been A Big Success

Wireless Data Has Failed In The Larger
Mobile Professional Market
Why?